

# Repair, Maintenance & Adjustment Procedures A.I.R. I Air Inhalation Regulator 11-126-000

(Refer to schematic for part identification)

Prior to starting any repair or maintenance on the A.I.R. I, it should be tested to determine what, if any, problems exist with its performance. This will also aid in determining which components may require a closer inspection.

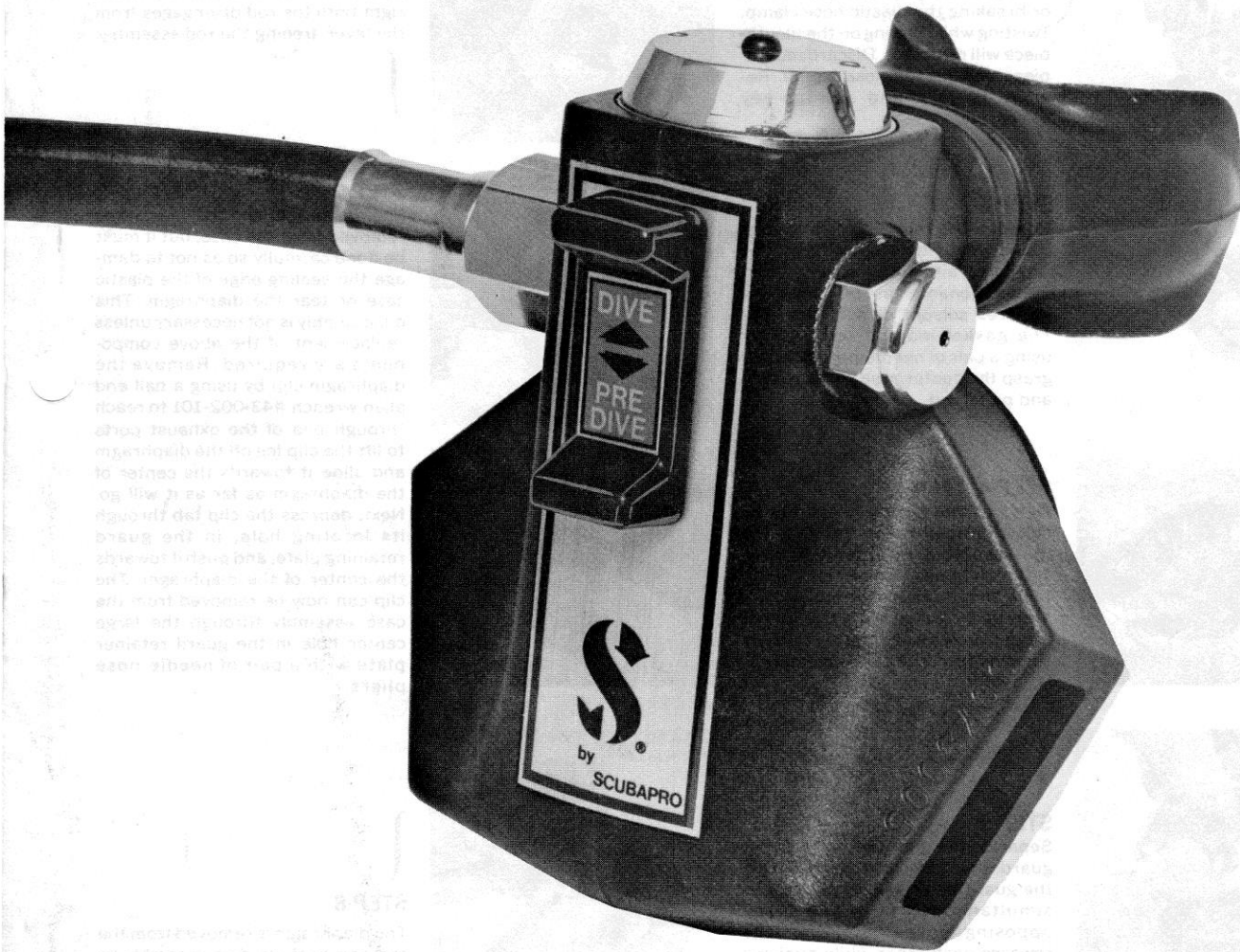

**SCUBAPRO®**

**41-911-126**

# A.I.R. I Air Inhalation Regulator Repair, Maintenance & Adjustment Procedures (Refer to schematic for part identification)

## DISASSEMBLY OF A.I.R. I

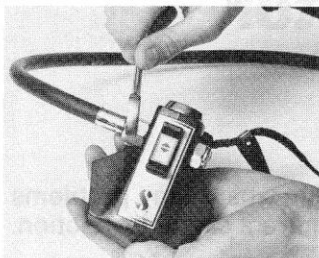

**STEP 1**  
Remove the A.I.R. I from the low pressure hose. Inspect low pressure hose for damage.

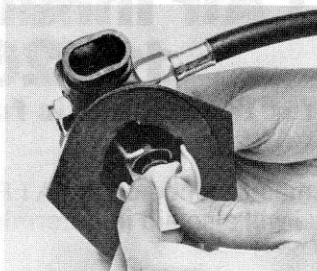

**STEP 6**  
Disconnect the diaphragm and rod assembly from the lever by first pulling the top half of the diaphragm through the large center hole in the guard retainer plate to expose the lever and rod. Then wrap the diaphragm around the hex on the back up disc so the hex can be grasped easily between the thumb and fingers. The hex is then pulled outward and pushed to the right until the rod disengages from the lever, freeing the rod assembly.

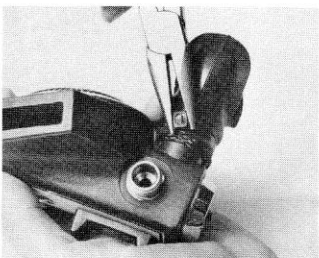

**STEP 2**  
Inspect mouthpiece for damage. Remove only if damaged, by cutting or breaking the plastic hose clamp. Twisting while pulling on the mouthpiece will remove it. Discard mouthpiece and plastic hose clamp. Remove lanyard and storage key assembly.

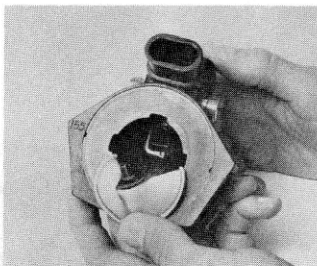

**STEP 3**  
Remove the inlet cap containing rubber seal. Remove seal from inlet cap only if air leakage was noted in pre-maintenance test or if inlet cap requires solvent or acid cleaning. The gasket may be removed by using a pair of needle-nose pliers to grasp the center area of the gasket and pull it out.

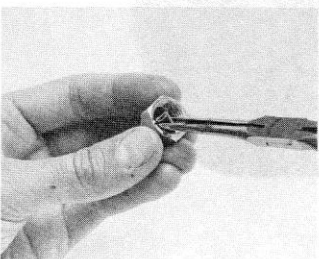

**STEP 4**  
Remove the guard assembly by inserting guard tool #43-001-101 into opposing holes and turning, 1/8 turn in either direction, to unlock the guard assembly. This should be done with the guard facing downward to aid in its removal from the case assembly.

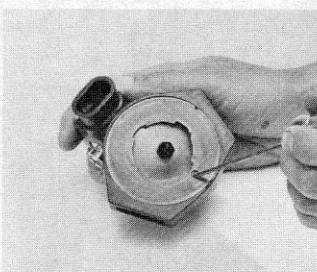

**STEP 7**  
The diaphragm and the clip can be removed from the case, but it must be done carefully so as not to damage the sealing edge of the plastic case or tear the diaphragm. This disassembly is not necessary unless replacement of the above components are required. Remove the diaphragm clip by using a ball end allen wrench #43-002-101 to reach through one of the exhaust ports to lift the clip leg off the diaphragm and slide it towards the center of the diaphragm as far as it will go. Next, depress the clip tab through its locating hole, in the guard retaining plate, and push it towards the center of the diaphragm. The clip can now be removed from the case assembly through the large center hole in the guard retainer plate with a pair of needle-nose pliers.

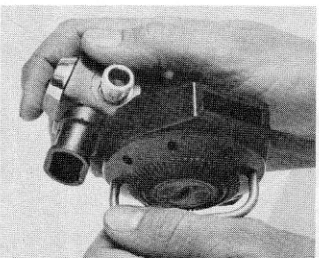

**STEP 5**  
Separate the guard o-ring from the guard, then remove the purge from the guard by using both thumbs to simultaneously push two of the opposing purge retaining legs towards each other while applying force to the leg ends. Do not cover purge with fingers, since this will restrict its removal. Separate the spring and purge. Inspect the four legs on the purge, if damaged or distorted discard the purge. Inspect the purge decal, remove and discard it only if it is not adhering properly or it has been damaged.

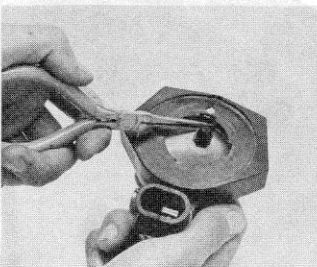

**STEP 8**  
The diaphragm is removed from the rod and back up disc assembly by pulling on one edge of the diaphragm while holding the rod and back up disc assembly. Inspect the diaphragm for damage (Per 41-903-003).

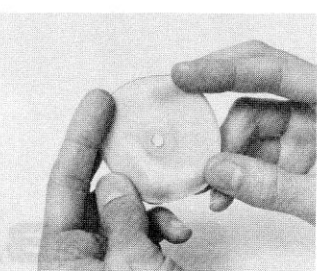
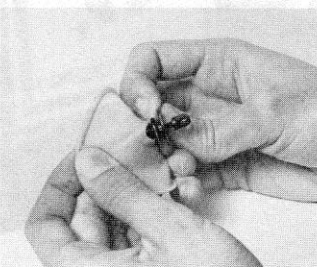
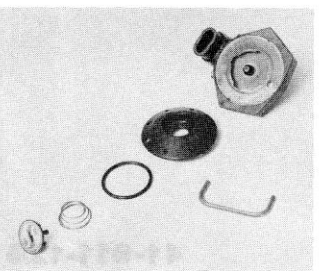
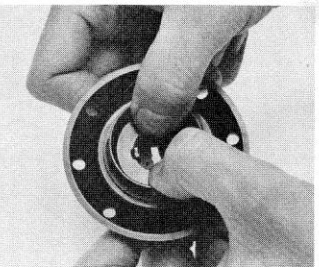

# A.I.R. I Air Inhalation Regulator

## Repair, Maintenance & Adjustment Procedures

(Refer to schematic for part identification)

### DISASSEMBLY OF A.I.R. I

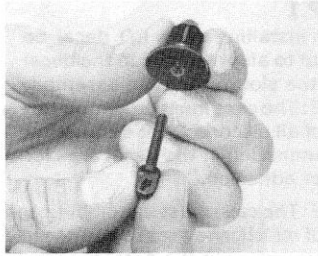

**STEP 9**  
The rod can be removed from the back up disc by unscrewing the rod (turn counterclockwise) while holding the back up disc.

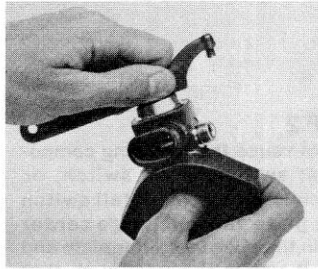

**STEP 10**  
The small plastic plug in the top of the cap is removed by lifting with a sharp tool or needle-nose pliers. Then, unscrew the cap (turn counter-clockwise) by using the spanner wrench #43-193-000. Remove the cap assembly and spring from the case assembly. Remove and inspect the cap o-ring for damage.

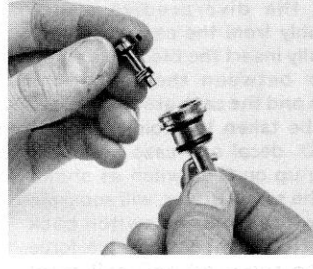

**STEP 14**  
The poppet assembly is removed from the housing assembly by using the lever to push the poppet assembly partially out. This also allows the lever to be removed. The poppet assembly can then be shaken out or pulled out of the housing assembly with a pair of needle-nose pliers. Carefully inspect the seat edge on the housing for any damage.

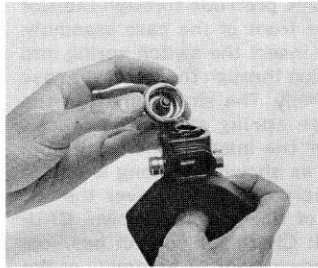

**STEP 11**  
The adjustable spring pad is removed from the cap by unscrewing it (turn counterclockwise). The small plastic plug can then be pushed out of the cap with the ball-end allen wrench #43-002-1-1, or other small tool.

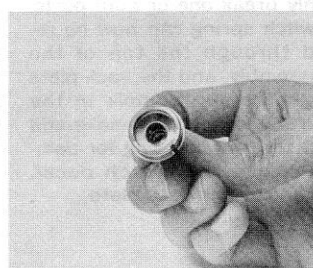

**STEP 15**  
Inspect the poppet assembly for damage and excessive wear on the end of the square where the lever contacts the poppet. Excessive wear will show up as an arc cut into the base of the square. If the condition of the poppet assembly is unacceptable, discard both the poppet assembly and the poppet o-ring. If the poppet condition is acceptable, remove and discard only the poppet o-ring.

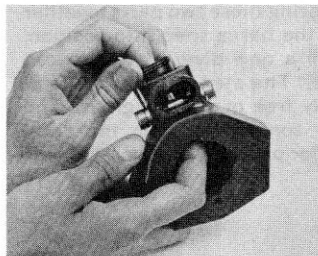
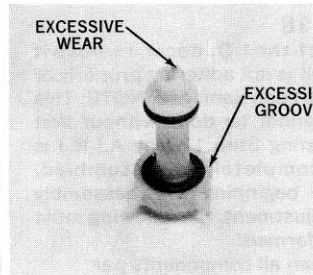

**STEP 12**  
The housing assembly is removed from the case assembly by applying a pushing force, with a finger, to the set screw in the housing and rocking the assembly back and forth.

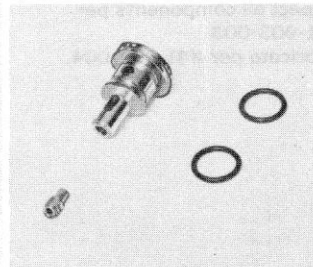

**STEP 16**  
Remove and inspect both housing o-rings for damage, then remove and discard the set screw by using ball end allen wrench #43-002-101, or a standard 3/32 allen wrench to unscrew it (turn counterclockwise).

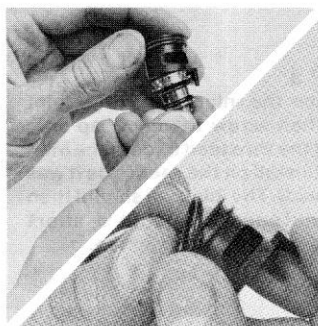

**STEP 13**  
To separate the aspirator and housing assembly, grasp the two parts as shown and exert force towards the thumbs with both index fingers to unsnap them. Remove and inspect aspirator o-ring damage.

# A.I.R. I Air Inhalation Regulator

## Repair, Maintenance & Adjustment Procedures

(Refer to schematic for part identification)

### DISASSEMBLY OF A.I.R. I

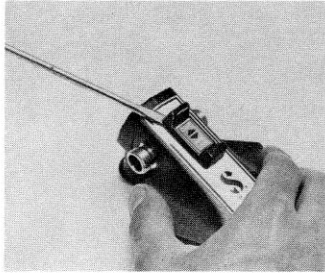

#### STEP 17

Dive/Pre-dive Switch Assembly  
**NOTE:** The dive/pre-dive switch rarely needs servicing, and unnecessary disassembly is not recommended because new switch components are required to reassemble. Do not attempt to reuse either of the plastic switch components once disassembled. To remove the dive/pre-dive switch assembly from the case assembly, carefully insert the blade of a screw driver between the top of the switch and the case assembly. Care must be taken to avoid damaging the I.D. decal and case assembly. Prying up on the switch as shown with the screw driver, will separate the switch from the switch back plate. **NOTE:** A considerable force may be required and will most certainly break one or both parts. The switch spring can now be removed through the top of the case assembly, and the back plate through the center hole in the guard retainer plate. Remove and inspect the switch o-ring for damage. Discard the switch decal, switch and switch back plate.

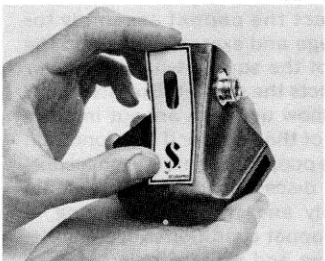
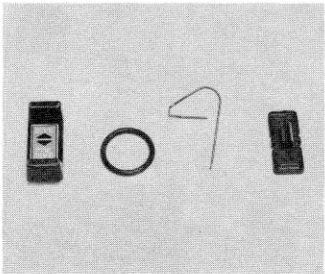
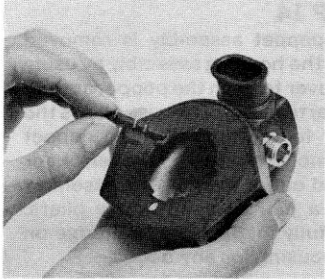

#### STEP 18

Inspect the I.D. decal, remove it only if it is not adhering properly or if it has been damaged. **NOTE:** This step cannot be done without first completing Step 17. The A.I.R. I is now completely disassembled. Before beginning the reassembly and adjustment, the following must be performed:

1. Clean all components per #41-903-002.
2. Inspect all components per #41-903-003.
3. Lubricate per #41-903-004.

### ASSEMBLY OF A.I.R. I

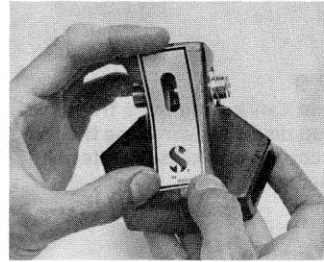

#### STEP 1

When installing a new I.D. decal, be careful to align the slot in the decal with the slot in the case assembly. **NOTE:** The case must be completely free of all silicone grease and other contamination in the decal area for proper adhesion.

**NOTE:** The case must be completely free of all silicone grease and other contamination in the decal area for proper adhesion.

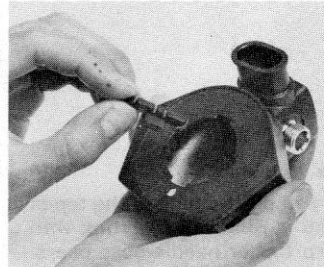

#### STEP 2

Do not reuse the following components: switch decal, switch, or switch back plate. Install switch back plate through large center hole in the guard retainer plate and slide it under the inlet such that the legs protrude through the slot in the front of the case assembly. Then insert the switch spring into position through the top of the case assembly. The short length of the switch spring should be placed **under** the inlet on the right-hand side, as shown. The long length of the spring is placed **over** the left side of the inlet, as shown. **CAUTION:** Check for correct position, as shown **prior** to assembly of the snap switch to avoid replacing components damaged by disassembly by improper assembly. Then pull the top of the switch plate back away from the case assembly far enough to slip the center portion of the switch spring into the top groove of the switch back plate. Lubricate the switch o-ring (per 41-903-004 static o-ring section) and install it in the groove on the switch, then take the switch and o-ring assembly and push it onto the legs of the switch plate by firmly squeezing these two parts together until the barbs snap into position. Install a new dive/pre-dive decal. **NOTE:** The switch must be completely free of silicone grease and other contamination in the decal area for proper adhesion.

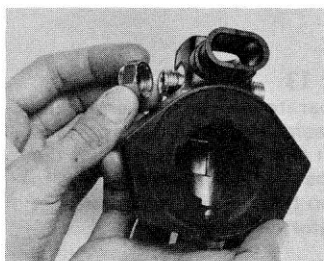
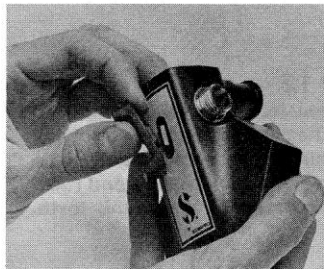
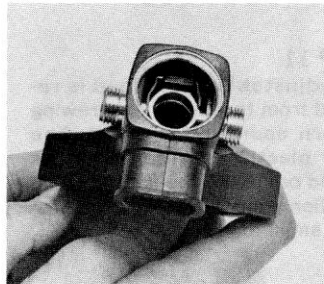

#### STEP 3

Replace the inlet seal in the inlet cap, then screw the inlet cap onto one of the threaded ends of the inlet tube (install on the same side it was removed). The inlet cap should then be tightened by using a short wrench. Do not over tighten.

# A.I.R. I Air Inhalation Regulator

## Repair, Maintenance & Adjustment Procedures

(Refer to schematic for part identification)

### ASSEMBLY OF A.I.R. I

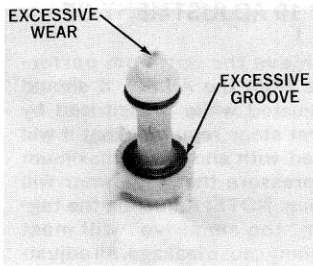

#### STEP 4

The poppet assembly and the poppet o-ring are the most commonly replaced items to improve regulator performance. Deep grooving of the sealing area, or excessive wear at the area of lever contact, will result in poor performance and necessitate replacement. The sealing edge of the housing should be checked for a clean, sharp edge, free of nicks. Any damage to this area will cause air leakage. Before assembly of the poppet assembly and the housing, clearance of the poppet assembly fit must be checked with respect to the housing. Without the poppet assembly o-ring installed, insert the poppet assembly into the housing. The poppet assembly should fit easily into the housing and not bind on the ends of the four protrusions on the base of the poppet. When gently tapped upside-down, the poppet assembly should fall freely from the housing. The poppet assembly can be inserted in any of its four positions. If any binding of the poppet assembly occurs, do not use it in that position, rotate it 90° and repeat the binding test. Repeat this until a free position is found; and if no free position is found, obtain a new poppet assembly and repeat the above. Note the poppet assembly position in the housing, then remove it.

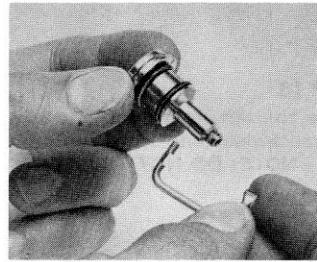
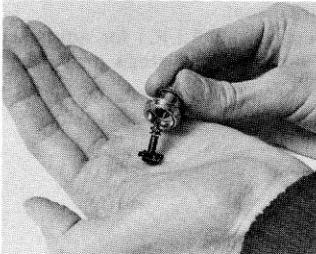

#### STEP 8

Install the lever in the housing. NOTE: Insert the lever through the lever slot from the side opposite the aspirator locating groove.

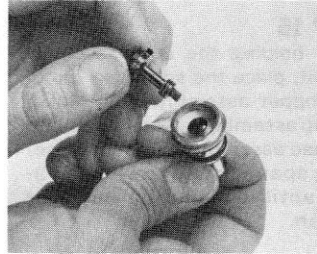

#### STEP 9

Install the poppet assembly in the housing in the same position noted in Step 4.

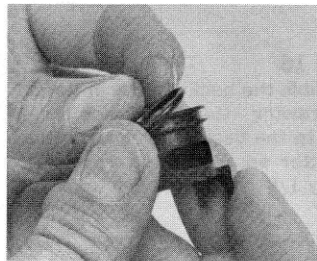

#### STEP 10

Lubricate the aspirator o-ring (per 41-903-004 static o-ring section) and install it on the aspirator.

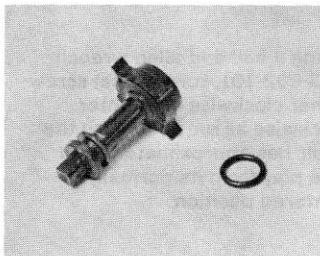

#### STEP 5

Lubricate the poppet o-ring (per 41-903-004 dynamic o-ring section) and install it on the poppet assembly. Note—the o-ring groove must be absolutely clean prior to lubrication and assembly, to prevent air leakage.



#### STEP 11

Assemble the aspirator to the housing by first aligning the locating pin inside the aspirator with the locating groove on the housing, then snapping the aspirator over the groove in the housing.

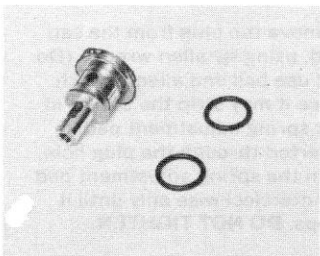

#### STEP 6

Lubricate the (2) housing o-rings (per 41-903-004 static o-ring section) and install them on the housing.

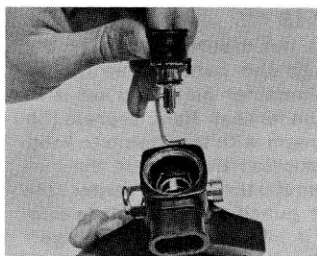

#### STEP 12

Assemble the aspirator and housing assembly into the case assembly. The legs on the aspirator straddle the inlet on the right-hand side of the case assembly. Firmly push the assembly into the inlet to seat it properly while checking to make sure that the switch spring does not get caught under the housing.

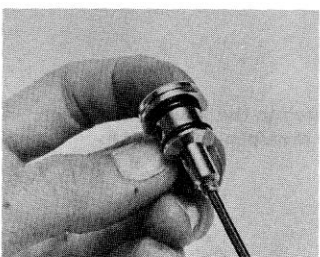

#### STEP 7

Install a new housing set screw in the housing and tighten with a 3/32" allen wrench (CAUTION: Do not use a ball-end allen wrench to initially tighten a new set screw since it may strip the socket head of the set screw) until the nylok (plastic insert in set screw) pellet just enter the in housing.



#### STEP 13

Lubricate the cap o-ring (per 41-903-004 static o-ring section) and install it on the cap.

# A.I.R. I Air Inhalation Regulator

## Repair, Maintenance & Adjustment Procedures

(Refer to schematic for part identification)

### ASSEMBLY OF A.I.R. I

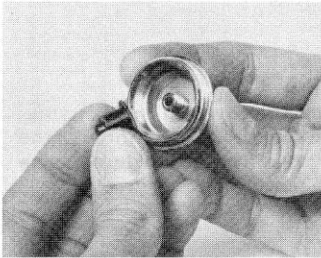

#### STEP 14

Screw the spring adjusting pad (turn clockwise) onto the cap until it stops—**NOTE: DO NOT TIGHTEN!**

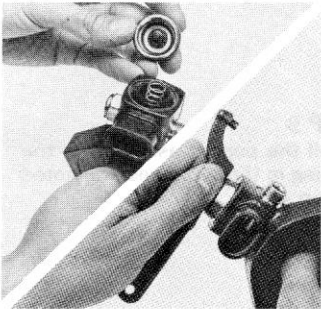

#### STEP 15

While holding the case assembly upright, place the spring on top of the poppet assembly, then install the cap assembly by screwing it into the case assembly (turn clockwise) using spanner wrench #43-193-000, until it stops. Do not over tighten.

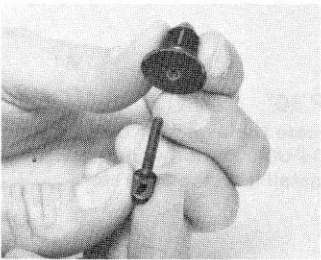

#### STEP 16

Assemble the back up disc and rod by screwing (turn clockwise) the rod into the back up disc until the shoulder on the rod is approximately 1/8" from the back up disc.

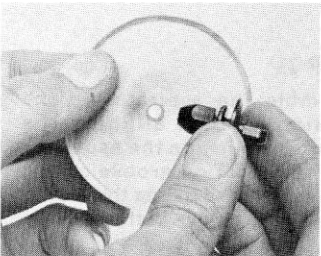

#### STEP 17

Assemble the diaphragm and back up disc assembly by inserting the hex end of the back up disc assembly through the center hole in the diaphragm, (NOTE: the side of the diaphragm with the beaded edge must be towards the back up disc.) until it seats in the first groove.



#### STEP 18

Insert the diaphragm assembly through the center hole in the guard retainer plate and set it in place on its seat. Next, depress the diaphragm with the thumb to keep it in position then insert the diaphragm clip through the center hole in the guard retainer plate and push it into place with a finger. Visually check through the exhaust ports to be sure the diaphragm and the clip are in their proper positions. If they are not, use the ball end allen wrench #43-002-101 to move them into their proper places.

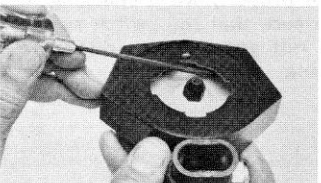

**NOTE:** The diaphragm should lay flat and not be pinched or buckled under the diaphragm clip, and the tab on the diaphragm clip must be in its locating hole in the guard retainer plate. **CAUTION:** Take care not to damage the diaphragm.

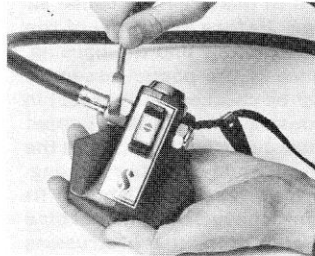

#### STEP 19 ADJUSTMENT OF A.I.R. I

To achieve the optimum performance from the A.I.R. I, it should be adjusted while pressurized by the first stage regulator that it will be used with and at the maximum tank pressure that the owner will be using. **NOTE:** Adjusting the regulator "too sensitive" will most commonly cause leakage. All adjustments should be made as sensitively as possible, but still provide a positive seal.

To prepare the A.I.R. I for adjustment the following steps must be completed:

A. Attach to first stage regulator

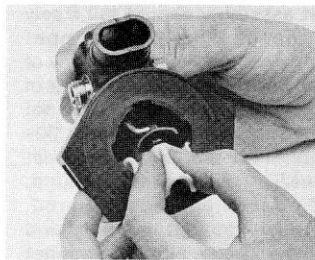

B. Detach the rod from the lever (refer to steps 4, 5, & 6 disassembly), if attached.

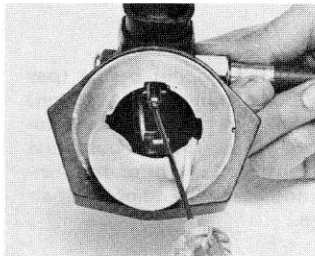

C. Using a ball end allen wrench #43-002-101, turn the set screw either clockwise or counterclockwise as required until the lever has approximately 1/4" of free play from its normally centered position.

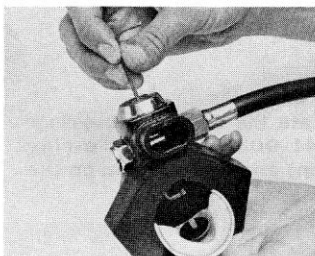

D. Remove the plug from the cap and, using 3/32" allen wrench (Do not use ball end allen wrench since it may strip the socket in the spring adjustment pad) inserted through the plug hole, turn the spring adjustment pad counterclockwise only until it stops. **DO NOT TIGHTEN.**



E. Switch to the "dive" position on the dive/pre-dive switch.

# A.I.R. I Air Inhalation Regulator

## Repair, Maintenance & Adjustment Procedures

(Refer to schematic for part identification)

### ASSEMBLY OF A.I.R. I

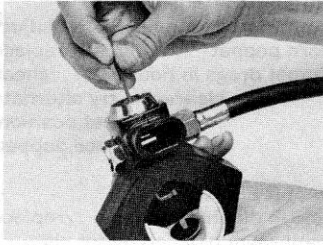

There are four possible adjustments for the A.I.R. I. They are as follows:

1) poppet spring tension, 2) lever adjustment, 3) switch spring position, and 4) diaphragm height. These four adjustments should be made in this sequence to achieve maximum performance and easiest breathing.

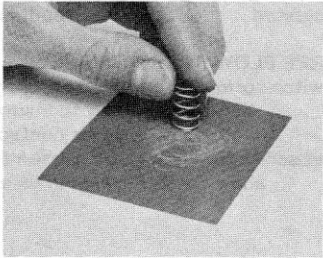

1. Pressurize the unit and, using a  $\frac{1}{32}$ " allen wrench inserted through the plug hole in the cap, turn the adjustable spring pad clockwise slowly. This will increase the spring tension and allow the spring to rotate into the best position for positive seating. Keep turning until the air leakage stops completely, then back off slightly to relieve any uneven torque on the spring. Work the lever several times to insure positive sealing of the poppet assembly. To achieve the finest tuning, try to adjust the spring until the poppet assembly seals positively with the least amount of spring tension. If the spring is not free to rotate (this is easily seen by looking into the mouthpiece), it may prove difficult to properly seat the poppet assembly. Remove the spring and polish one end with a piece of fine emery, then re-assemble with the polished end contacting the top of the poppet assembly, so it will turn freely while adjusting. If leakage cannot be stopped, check to be sure that the set screw is loose enough to allow free play of the lever.

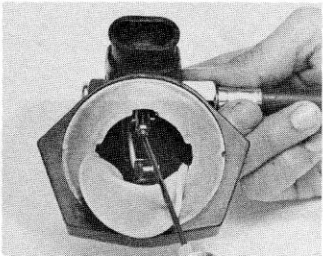

2. Once the spring tension is adjusted and there is no leakage, adjust the set screw using a ball end allen wrench #43-002-101 to turn it clockwise to remove the lever free play. Tighten the set screw until a slight leak is heard, then back off slightly until there is about  $\frac{1}{16}$ " free play before the lever begins to operate the poppet assembly. Operate the lever several

times to make sure the seating is positive. Depress the lever fully to make sure that it will travel freely until it contacts the inside of the plastic case. If any restriction is noted, the spring pad has been adjusted too tightly and should be readjusted. **CAUTION:** Hold the ball end wrench at as low an angle to the case assembly as possible while adjusting to avoid stripping the socket head screw.

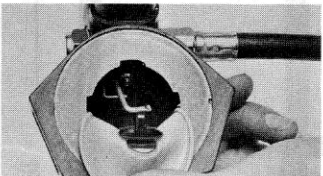

3. Check the position of the dive/pre-dive switch spring by switching to the pre-dive position and visually verifying that the spring is just contacting the lever without causing air leakage. The switch spring should also provide sufficient tension to prevent free flow in the pre-dive position. If the switch spring requires adjustment, bend the spring into the proper position by using a spring adjusting tool, or long nosed pliers which can be made to the specifications shown in the tool section.

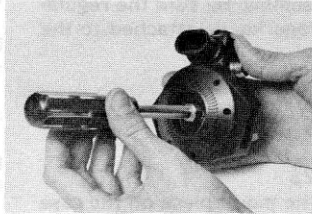
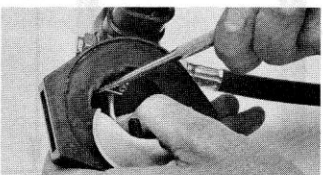

4. Shut off the air source and switch to the dive position. Reattach the rod to the lever and reseat the diaphragm. Next, install the guard o-ring (lubrication of the guard o-ring is not required) and guard. The diaphragm should be adjusted so that it is sitting flat against its seating edge, and begins to open the poppet assembly seat at the slightest inhalation without hesitation, but provides positive air shut off. Check this with with A.I.R. I diaphragm facing downward to avoid adjusting the diaphragm too sensitive. To adjust the diaphragm, pressurize the unit then carefully turn the hex on the back up disc by using a  $\frac{3}{8}$ " socket. Turning the back up disc clockwise will lower the diaphragm, and turning counterclockwise will raise it. **NOTE:** Adjusting the diaphragm while the unit is pressurized may be annoying if the diaphragm is depressed, since it will start free flowing. You may wish to turn the air supply off during actual adjustment then repressurize to test.

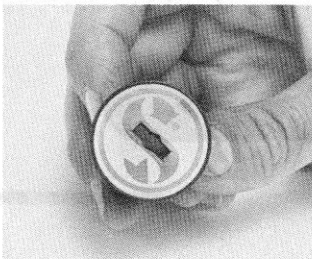

#### STEP 20

When installing a new purge decal, be careful to align the slot in the decal with the slot in the purge. **NOTE:** The purge must be completely free of all silicone grease and other contamination in the decal area for proper adhesion.

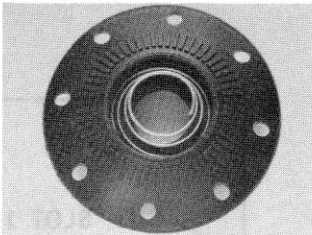

#### STEP 21

Place the purge spring in the guard (large end first) then assemble the purge to the guard by first locating the "S" in the proper orientation, then pressing the purge into the hole in the guard until the legs snap into place, locking it in.

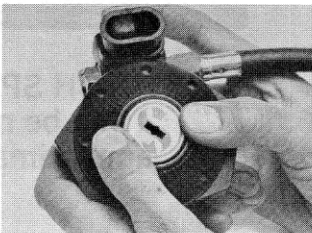

# A.I.R. I Air Inhalation Regulator

## Repair, Maintenance & Adjustment Procedures

(Refer to schematic for part identification)

### ASSEMBLY OF A.I.R. I

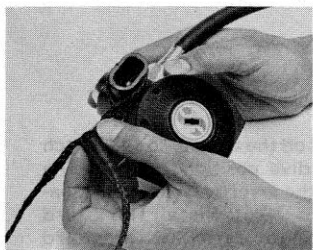

#### STEP 22

Slip the loop of the lanyard over the mouthpiece retainer on the case assembly. Be sure the regulator storage key is attached to the lanyard.

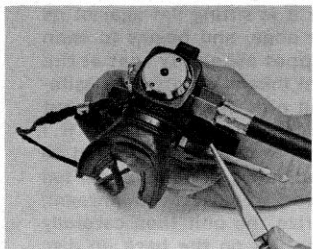

#### STEP 23

Install the mouthpiece on the case assembly, then secure in place by installing a new mouthpiece strap in the groove provided on the mouthpiece, and pull tight with a pair of pliers. Do not exceed 30 lbs. pull. The ratchet action of the mouthpiece strap allows only one way movement, and it cannot be loosened once the slack is drawn out. Trim off the excess plastic band, making it flush with the top of the square lug.

#### STEP 24

Check unit for ease of breathing and leakage. When adjustment is satisfactory, replace small plastic plug in top of cap. Shut off air supply, purge the unit of air, then insert the regulator storage key to prevent the poppet assembly seat from taking a set and causing an air leakage.

### TROUBLE-SHOOTING

#### AIR LEAKAGE—

- Diaphragm height incorrect . . . . . readjust
- Set screw too tight . . . . . loosen
- Insufficient poppet spring tension . . . . . tighten
- Poppet spring not rotating during adjustment . . . . . polish ground end of spring & replace
- Faulty poppet assembly o-rings . . . . . replace
- Faulty housing o-rings . . . . . replace
- Housing sealing edge damaged . . . . . replace
- Interference of switch spring in "pre-dive" position . . . . . bend away from lever
- Damaged poppet assembly seat . . . . . replace

**NOTE:** If source of leak cannot be determined, peel back the top of the diaphragm, disconnect rod, and place in water-filled container. Air bubbles coming from the base of the housing near the lever indicate the poppet assembly o-ring is leaking; bubbles from the aspirator indicate that the poppet is not sealing at the housing seat; and bubbles at the inlet and housing juncture indicate a leak at the housing o-rings.

#### HARD BREATHING—

- Improper adjustment . . . . . readjust
- Worn poppet . . . . . replace
- Poppet drags in housing . . . . . check clearance, try alternate poppet position, replace poppet.

#### WATER LEAKS—

- Hole in diaphragm . . . . . replace
- Diaphragm pinched under clip . . . . . reset
- Diaphragm height improperly adjusted . . . . . readjust

#### FREE FLOW IN PRE-DIVE—

- Switch spring not adjusted properly . . . . . bend accordingly to insure lever contact
- Set screw too tight . . . . . loosen to allow 1/16" free travel in lever

### A.I.R. I REGULATOR SPECIAL TOOLS REQUIRED

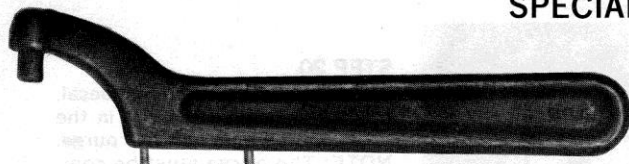

43-193-000  
SPANNER WRENCH

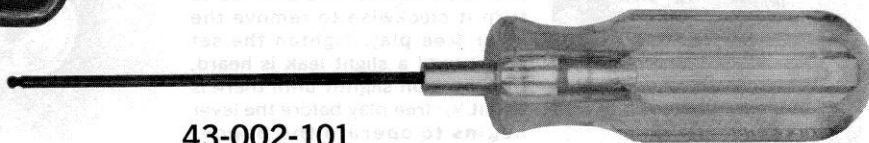

43-002-101  
BALL-END ALLEN WRENCH

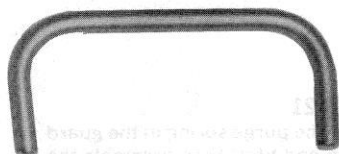

43-001-101  
GUARD  
INSTALLATION  
TOOL

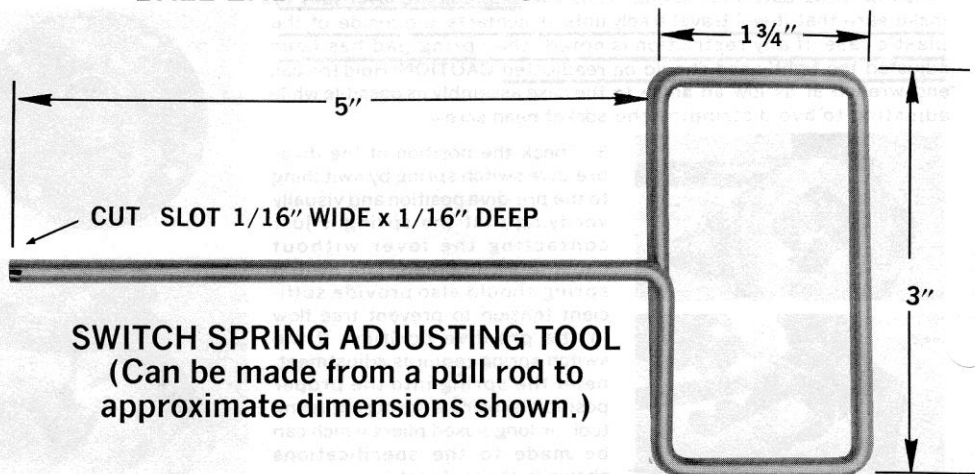

SWITCH SPRING ADJUSTING TOOL  
(Can be made from a pull rod to approximate dimensions shown.)